



YANMAR

COMPACT TRACTOR

GK Series

16 HP - 20 HP



Call for Yanmar solutions



the latest integrated design for advanced technology

TECHNOLOGY YOU DEMAND

YANMAR tractors are well established throughout Europe, designed and built to make light of the heaviest applications across farms or in larger gardens. Not only in Europe, but worldwide, people rely on YANMAR engineered agricultural products.

GK Series tractors are the most compact in the YANMAR range. Smaller in dimensions but with all the tractor technology you demand, the most compact tractors from YANMAR are as powerful and versatile as the biggest models in the line-up.

ENGINEERED STRENGTH

YANMAR's GK Series has all the power to complete a diversity of jobs for you with ease and comfort, yet these tough, durable tractors are extremely compact in design. Their engineered strength will allow you to handle much larger tasks while the compactness enables tighter turns and smoother handling.



Design Tractor power



The GK Series is a further result of YANMAR's Solutioneering together. With decades of experience in developing and building tractors, YANMAR offers you yet another series of tractors to exceed all expectations. Benefit from the Japanese quality of build and feel the built-in dedication to your needs as you work with this advanced technology.

It is time to start enjoying your work with a new tractor from YANMAR.

THE COMPACT GK 160

For the European market the YANMAR GK 160 is the first to be offered from the new, compact GK Series. With models at 16 HP and 20 HP, available in different combinations, there will be a GK 160 to fit your every requirement.

The tractor is equipped with a three point linkage and has a lifting capacity of 550 kg. This makes this highly efficient unit a very powerful workhorse. The economical YANMAR diesel engine is strong and runs quietly and smoothly.

Power is transferred to the wheels via an ultra-efficient transmission and gives you that extra traction you may need. Many agricultural and garden implements can be used in combination with the GK 160.

The most compact YANMAR tractor on the market can do big things for you. Harness the power to improve your productivity.

OVERVIEW FROM PLATFORM

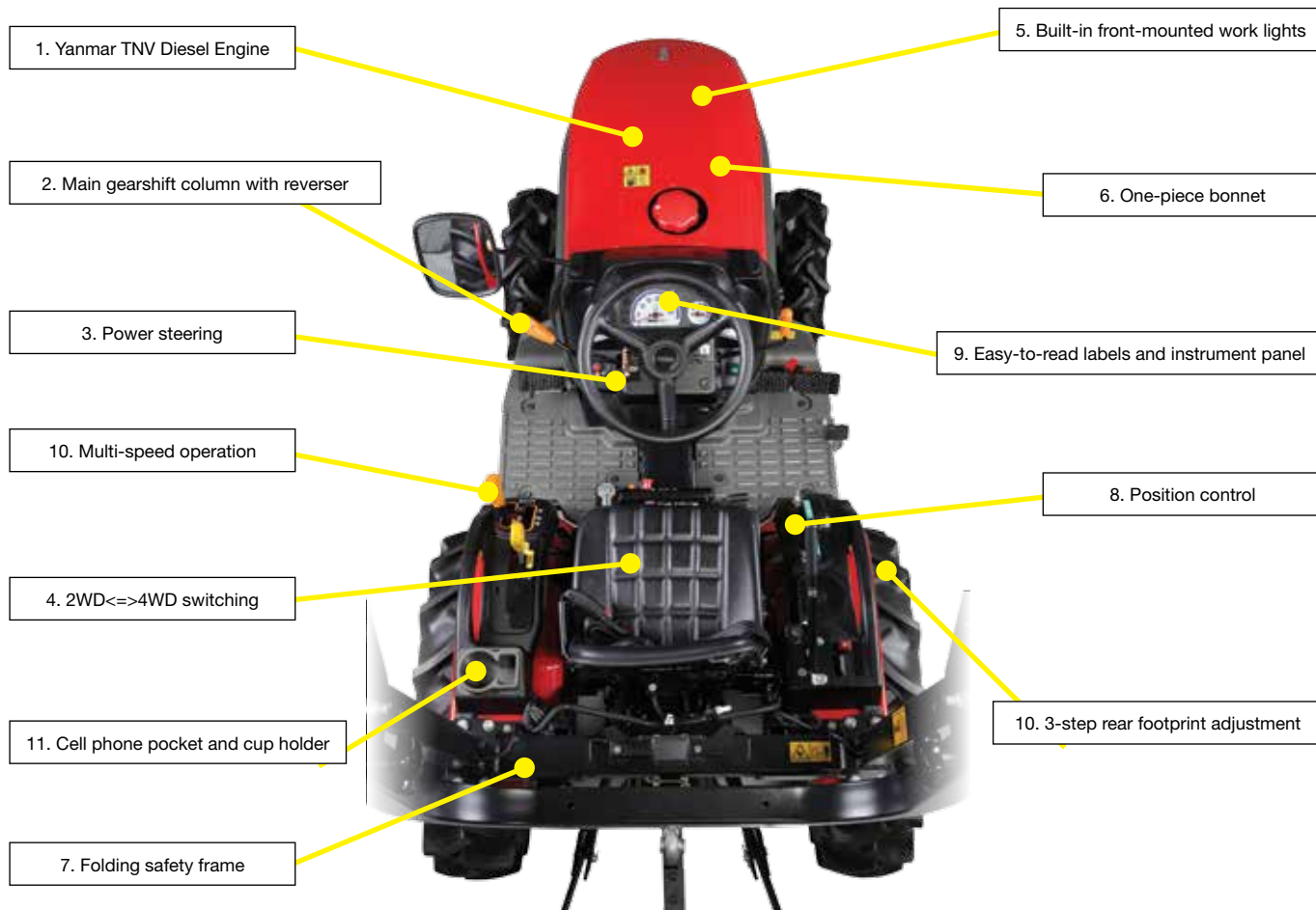

FEATURES FROM GK



YANMAR TNV DIESEL ENGINE
 GK Series tractors come with a compact and powerful 3-cylinder liquid cooled diesel engine developed through Yanmar's original technology. This diesel engine provides tough, indefatigable work capacity, offers better mileage than petrol engines, and also excels in durability.



MAIN GEARSHIFT COLUMN WITH REVERSER
 A single lever handles both standard gearshift operation and switching to forward/reverse. Situated to the left of the steering wheel, this lever was designed for operator-friendly operation.

POWER STEERING - STANDARD EQUIPMENT

Fully hydrostatic power steering is standard function in the GK tractor same as a large-scale tractor. It enables you to make turn the wheel with a minimum effort. It makes overall handling easier and lessens driving fatigue even over long hours or during work that requires turning frequently.



ONE-PIECE BONNET

The bonnet's one-piece construction makes opening and closing easy. As a result, the tractor is just that much more simple to maintain.



BUILT-IN FRONT-MOUNTED WORK LIGHTS

Work lights, located in front on both the right and left sides, brightly and safely illuminate the terrain ahead of the tractor.



2WD <=> 4WD SWITCHING

4-wheel drive offers better traction on soft ground, and delivers greater power during work as well. Simple switching to 2-wheel drive prevents damage to turf and other delicate ground during turns.



FLAIL MOWER



ROTARY TILLER



FINISHING MOWER



CULTIVATOR



TRANSPORT BOX



TRAILER



SHREDDER

DIMENSIONS AND WEIGHTS

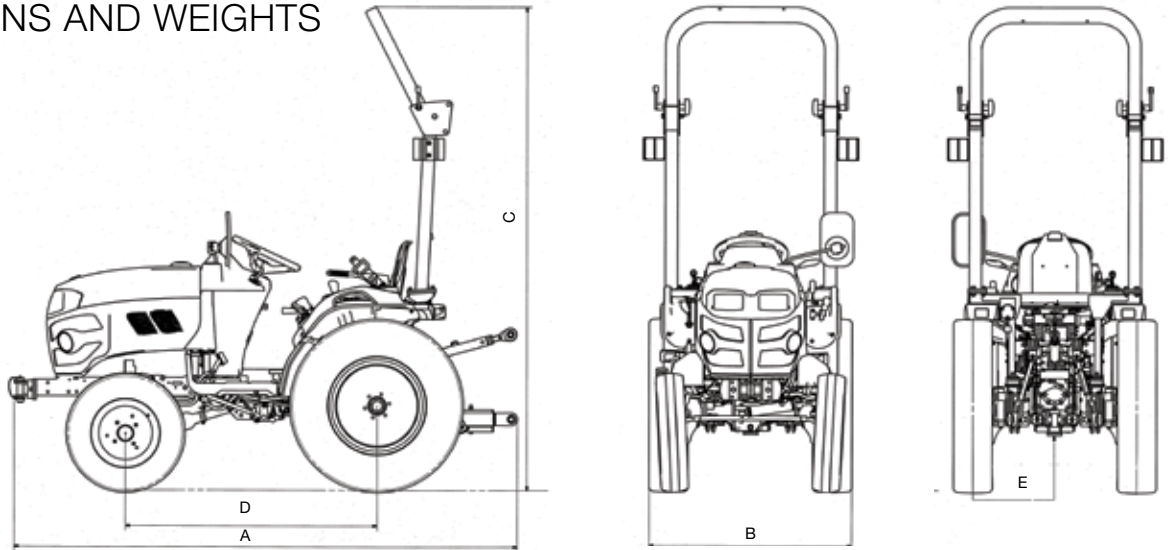

KEY	Tire combination	FRONT		4.5-10	5-12	5.00-12	20x8.00-10	23x8.5-12
		REAR		7-16	8-16	8-18	212/80-15	9,5x16TL
A	Overall length including lower link		[mm]	2460				
B	Maximum overall width		[mm]	1049	1049	1090	1065	1040
C	Overall height including ROPS		[mm]	2316	2340	2361	2306	2367
D	Wheelbase	GK160	[mm]	1227				
		GK200	[mm]	1277				
E	Minimum ground clearance		[mm]	217	241	262	207	268
	Tractor weight	GK160	[kg]	590	600	615	600	-
		GK200R	[kg]	-	-	695	670	670

Model			GK160	GK200R
Engine	Type		Water-cooled, 4 cycle diesel	
	Injection system		Indirect injection	
	Model		3TNV70	3TNV76
	Displacement	[cc]	853	1115
	Rated output	ECE-R24		11.1 kW / 2400 rpm
			[15.1 HP / 2400 rpm]	[19.3 HP / 2400 rpm]
Gross horse power			15.6 HP / 2400 rpm	20.5 HP / 2400 rpm
Steering		Hydraulic full power steering, standard		
Brake		Mechanical, wet multiple disc		
Transmission	Range		8 forward / 4 reverse	
	Main shift		2 forward, 1 reverse, mechanical	
	Range shift		4 speed, mechanical	
	Differential lock		Mechanical, standard	
Travelling speed at rated engine speed	Forward	Km/h	0.50-12.14	
	Reverse	Km/h	0.40-6.31	
Rear PTO	Type		Mechanical	
	Shaft		Type 1, 35mm, 6 spline	
	Speed	rpm	540 at 2339 rpm engine speed 579 at 2400 rpm engine rated speed	
Electrical	Battery		12V-36AH	
	Alternator		12V-40AH	
Three point rear linkage	Type		Category 1N	
	Control		Position control	
	Maximum lifting capacity		550 kg at lower link end	
Trailer coupling	Type		Drawbar, standard	
Safety	ROPS		Standard	
	Seatbelt		Standard	

SPECIFICATIONS

The company reserves the right to change the above specifications without notice. EC approved.

OPTIONAL EQUIPMENTS



RH SIDE REAR VIEW MIRROR

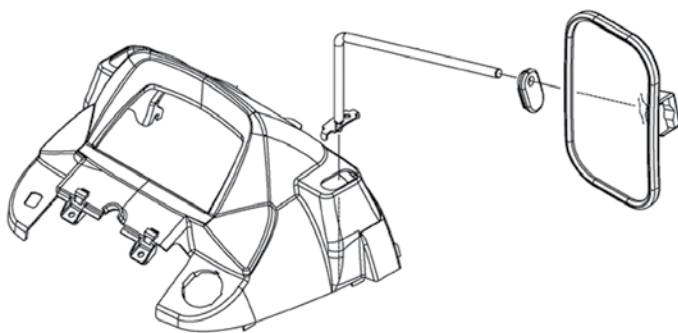

FRONT WEIGHT 20KG

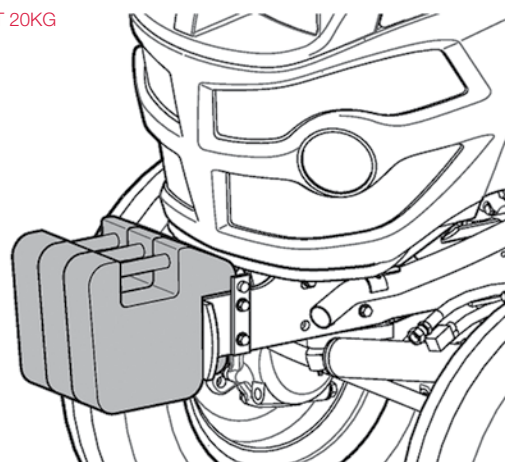

PARTS AND SERVICE



SPARE PARTS

In order to maintain the performance and durability of Yanmar tractors, using genuine parts is a must. The same can be said for repairing and servicing of the Yanmar tractors. You are always close to use. From our factories to Kobe [Japan] distribution centre genuine parts are forwarded to our large logistic hub near Amsterdam. From there we serve Europe.



SERVICE & WARRANTY

Service partners all around Europe are educated to offer you service wherever you like. Service engineers are trained by Yanmar to guarantee the quality of the work. Yanmar offers a limited warranty of 2 years on all tractors. In this case you can work with your tractor without any worries.

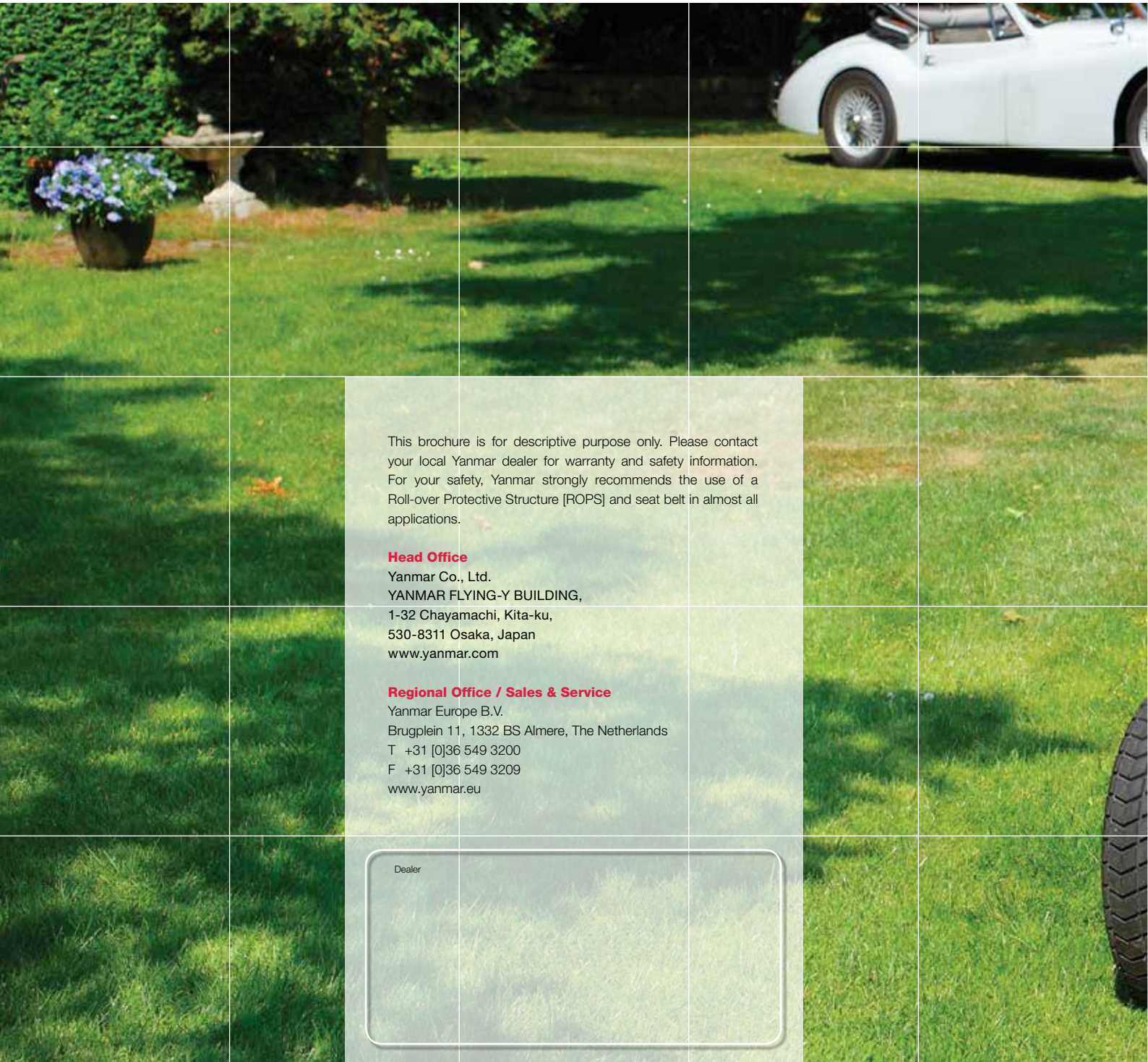

This brochure is for descriptive purpose only. Please contact your local Yanmar dealer for warranty and safety information. For your safety, Yanmar strongly recommends the use of a Roll-over Protective Structure [ROPS] and seat belt in almost all applications.

Head Office

Yanmar Co., Ltd.
YANMAR FLYING-Y BUILDING,
1-32 Chayamachi, Kita-ku,
530-8311 Osaka, Japan
www.yanmar.com

Regional Office / Sales & Service

Yanmar Europe B.V.
Brugplein 11, 1332 BS Almere, The Netherlands
T +31 [0]36 549 3200
F +31 [0]36 549 3209
www.yanmar.eu

Dealer

www.yanmar.eu